

Year 12 Mathematics Specialist 2018

Test Number 5:

Rates of Change and Differential Equations

Resource Free

Name: _____

Teacher: DDA

Marks: 36

Time Allowed: 35 minutes

Instructions: No notes or calculators. Show your working where appropriate remembering you must show working for questions worth more than 2 marks.

Question 1**[2, 2, 2 = 6 marks]**Find $\frac{dy}{dx}$ if:

a) $x^4 + 5y^3 = 17$

b) $e^x + e^{2y} = x^2$

c) $x \cos x = \sin y$

Question 2**[3, 6 = 9 marks]**

Solve the following differential equations expressing your answers in the form $y = f(x)$

a) $\frac{dy}{dx} = 2y^4$

b) $\frac{dy}{dx} = \frac{xy-6y}{x^2-4}$ given that when $y = 1, x = 3$.

Question 3**[3 marks]**

Match the slope fields to the differential equations:

a) $\frac{dy}{dx} = y + 1$

b) $\frac{dy}{dx} = x - y$

c) $\frac{dy}{dx} = x - y^2$

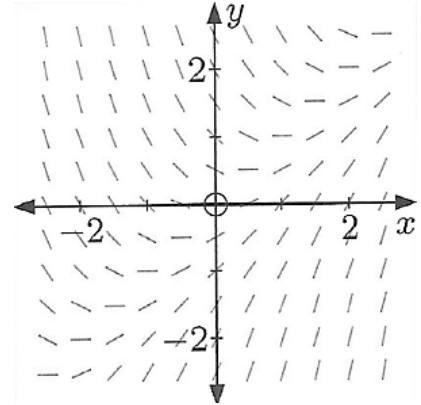
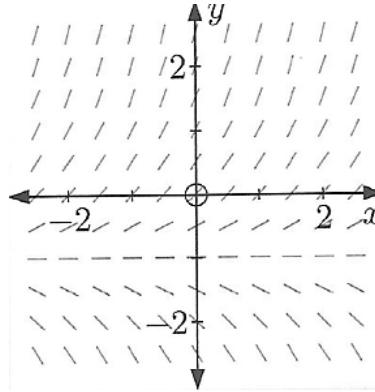
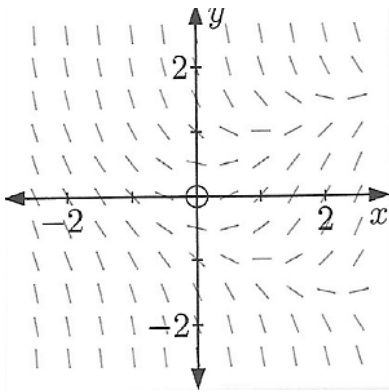
**Question 4****[1, 2 = 3 marks]**The slope field for $\frac{dy}{dx} = \frac{1-x^2-y^2}{y-x+2}$ is shown.

- a) Find the gradient of the tangent to the solution curve at (1,1).

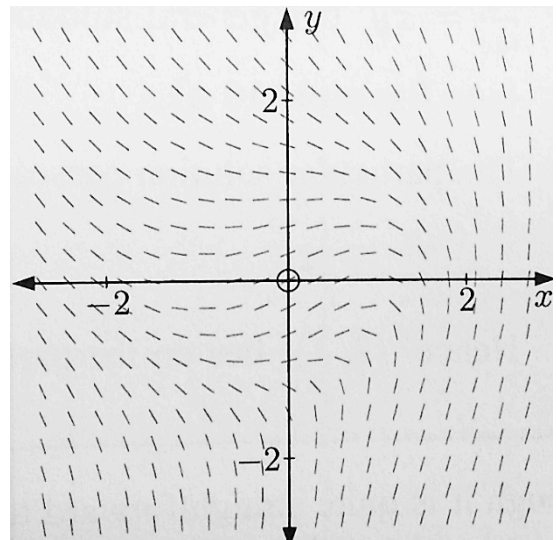

- b) Sketch the solution curve which passes through (1,1).

Question 5**[2,2 = 4 marks]**

The velocity of v m/s of particle P is related to its displacement x m from a fixed origin point O by the equation $v = x^3 - 8$. It is known that P starts off at O .

a) Determine the acceleration when $x = 1$ m.

b) Determine its displacement when its acceleration is 0.

Question 6**[2 marks]**

The cost function for a particular item is given by $\$c$ where $c = 450 + 0.5x^2$ and x is the number of such items produced.

Find the marginal cost for $x = 10$ and explain what this tells you about the cost of producing one more item at this level of production.

c) Write x in terms of t .

d) Find the position, velocity and acceleration of the object after $\frac{7\pi}{12}$ seconds.

Year 12 Mathematics Specialist 2018

Test Number 5:

Rates of Change and Differential Equations

Resource Rich

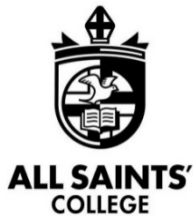

Name: _____

Teacher: DDA

Marks: 12

Time Allowed: 15 minutes

Instructions: You are permitted 1 A4 page of notes and your calculator. Show your working where appropriate remembering you must show working for questions worth more than 2 marks.

Question 8**[4, 1, 3 marks]**

An ecology student is studying the repopulation of wild emus in South Australia after a drought.

She notices that the population growth rate is approximately logistic so that $\frac{dP}{dt} = gP \left(1 - \frac{P}{A}\right)$ where $P(t)$ is the population t years after her study begins.

The carrying capacity A is known to be 2550 emus since this was the population before the drought.

Initially, the student finds that there are 310 emus. After two years she finds there are 390 emus.

- a) Solve the differential equation, using the population $P(0)$ and $P(2)$, to find an expression for the population $P(t)$ after t years.

- b) Estimate the emu population after 5 years.

c) Find the time at which the population growth rate, $\frac{dP}{dt}$, is a maximum.

Question 9

[4 marks]

A man on a jetty pulls a boat towards him by hauling a rope at the rate of 20 metres per minute. The rope is attached to the boat 1 m above water level, and the man's hands are 6 m above the water level. How fast is the boat approaching the jetty at the instant when it is 15 m from the jetty? (Give answer to 1 dp)

